

Operator mixing and three-point functions in $\mathcal{N} = 4$ SYM

This article has been downloaded from IOPscience. Please scroll down to see the full text article.

JHEP10(2009)009

(<http://iopscience.iop.org/1126-6708/2009/10/009>)

[The Table of Contents](#) and [more related content](#) is available

Download details:

IP Address: 80.92.225.132

The article was downloaded on 01/04/2010 at 13:39

Please note that [terms and conditions apply](#).

Operator mixing and three-point functions in $\mathcal{N} = 4$ SYM

George Georgiou, Valeria L. Gili and Rodolfo Russo

*Centre for Research in String Theory, Department of Physics,
Queen Mary, University of London,
Mile End Road, London E1 4NS, U.K.*

E-mail: G.Georgiou@qmul.ac.uk, V.Gili@qmul.ac.uk, R.Russo@qmul.ac.uk

ABSTRACT: We study the three-point functions between two BPS and one non-BPS local gauge invariant operators in $\mathcal{N} = 4$ Super Yang-Mills theory. We show in explicit 1-loop examples that the single trace operator mixing due to planar quantum corrections, discussed in arXiv:0810.0499, plays an important role in the computations of the correlators. In particular, it is necessary to cancel contributions that would violate the constraints following from the superconformal and the bonus $U(1)_Y$ symmetries. We analyse the same type of correlators also at strong coupling by using the BMN limit of the $AdS_5 \times S^5$ string theory. Again the mixing between states with different types of impurities is crucial to ensure the cancellation of various amplitudes that would violate the constraints mentioned above. However, on the string side, we also find some examples of interactions between one non-BPS and two BPS states that do not satisfy expectations based on the superconformal and the bonus $U(1)_Y$ symmetries.

KEYWORDS: Supersymmetric gauge theory, AdS-CFT Correspondence, Penrose limit and pp-wave background

ARXIV EPRINT: [0907.1567](https://arxiv.org/abs/0907.1567)

Contents

1	Introduction	1
2	Operators	4
3	Correlators	9
3.1	$U(1)_Y$ violating correlators	9
3.2	A correlator involving a level-three non-BPS operator	15
4	Contributions of the operator mixing to non-trivial structure constants	17
5	Structure constants in the BMN limit	19
6	Discussion and conclusions	22

1 Introduction

The first important step in the description of a Conformal Field Theory (CFT) is represented by the identification of the primary operators and the knowledge of their conformal dimension. The second crucial characterisation of a CFT is given by the structure constants which determine the Operator Product Expansion (OPE) between two primary operators. $\mathcal{N} = 4$ Super Yang-Mills (SYM) theory is an important example of interacting four dimensional CFT which has been thoroughly studied because of the AdS/CFT duality with string theory [1]. In particular in the recent years huge progress has been made in the computation of the planar contribution to the conformal dimensions of non-protected operators. Comparatively very little is known about the structure constants. In principle it is possible to tackle this problem by using both the gauge and string theory descriptions. In the first case the structure constants are extracted from the 3-point correlators among gauge invariant operators, while in the second description one needs to compute the partition function of IIB string theory in $AdS_5 \times S^5$ with appropriate boundary conditions [2, 3]. Unfortunately neither of these approaches can be currently used to explicitly evaluate the structure constants as an exact function of 't Hooft coupling (λ) even in the planar limit.

Our current knowledge of the OPE coefficients is essentially based on a perturbative expansion around $\lambda = 0$, where standard Feynman diagrams can be used to evaluate the relevant gauge theory correlators, or around $\lambda = \infty$ where the IIB string theory is well approximated by a simpler description. By comparing the 3-point correlators among half-BPS operators in these two different limits, the authors of [4] conjectured that the corresponding structure constants are non-renormalised (i.e. they have a trivial dependence on the

't Hooft coupling). On the contrary the 3-point correlators among non-protected operators receive quantum corrections, as it is shown, for instance, by the correlator between three Konishi operators [5]. On the gauge theory side, the authors of [6–9] studied systematically the structure constants for operators with only bosonic fields and computed the corrections arising from the planar 1-loop Feynman diagrams. On the string theory side it is more difficult to extract information about non-protected OPE coefficients, since, in the supergravity limit, all non-protected operators acquire large conformal dimension and decouple. The BMN limit [10] represents a different approximation, where it is possible to extract useful information on non-BPS structure constants. In this framework the cubic Hamiltonian has been studied thoroughly [11–13] and in [14, 15] it was proposed how to combine these results and relate the PP-wave cubic Hamiltonian to the structure constants of the $\mathcal{N} = 4$ SYM.

In computing explicit examples of non-protected structure constant, one encounters a complication that is common to both the gauge and the string theory language: the knowledge of the conformal dimension of the operators is not sufficient, but one needs also their precise form in terms of the elementary degrees of freedom. In other words, it is necessary to know both the eigenvalues and the eigenvectors of the $\mathcal{N} = 4$ SYM dilatation operator. This point has been discussed explicitly in the gauge theory analysis of correlators that receive contributions from extremal diagrams [16, 17]. These 3-point correlators receive corrections at the leading order in N from the mixing between single and double trace operators, even if this mixing is irrelevant for the computation of the conformal dimensions. The aim of this paper is to show in explicit examples that another type of operator mixing, controlled by λ , plays a crucial role in the computation of the structure constants in both descriptions (and clearly on the gauge theory side it is relevant also for the correlators that do not have any extremal contribution). In particular we will focus on the operators in the non-BPS multiplet discussed in [18] which represents a generalisation of the usual Konishi multiplet. The mixing problem for these operators was discussed in [19] by studying the action of the conformal supercharges. In the examples discussed in sections 3 and 4 of this paper, one can see that the corrections due to the operator mixing just mentioned play a crucial role in the computation of the structure constants.

In our analysis we will pay particular attention to the 3-point correlators involving two half-BPS states and one non-BPS state. This class of correlators enjoys a special status and various results have been derived or conjectured by studying carefully the symmetries of the theory. For instance, in [20] it was proposed that the $U(1)_Y$ bonus symmetry should constrain the result of certain $\mathcal{N} = 4$ correlators. This $U(1)_Y$ is an exact symmetry of the theory only at the level of the equations of motion of the free theory $g_{YM} = 0$ and in the supergravity limit $\lambda \rightarrow \infty$. For finite values of the coupling, the symmetry is broken by the Yukawa coupling in the gauge theory language or by the string corrections on the bulk side. However, it is still possible to attach a $U(1)_Y$ quantum number to the various states of the theory by assigning charge $+1$ (-1) the supercharges transforming in the fundamental (anti-fundamental) representation of the global symmetry group $SU(4)$. Then if the highest weight states have $U(1)_Y$ charge zero, as in our example, we can read the charge of all descendants by looking at what level in the supermultiplet they are. In [21],

it was conjectured that 3-point correlators involving two half-BPS states and one non-BPS state should obey a selection rule and only the amplitudes that preserve the $U(1)_Y$ charge are expected to be non-trivial (on the contrary, when two or more non-BPS operators are present, there is no $U(1)_Y$ selection rule at work). The evidence provided in [21] for this conjecture includes both gauge theory perturbative computations and arguments on instanton corrections. Other results on this class of correlators were derived by studying the OPE of 4-point correlators among half BPS states [22, 23]. For instance, this analysis shows that the OPE of two protected operators with $SU(4)$ Dynkin labels $[0, p, 0]$ can generate only the non-BPS states that belong to multiplets whose highest weight state has labels $[n - m, 2m, n - m]$ with $m \leq n \leq p - 2$. Finally the strongest results on this class of correlators are derived by using the $\mathcal{N} = 4$ superspace which can make manifest the constraints of the superconformal Ward identities on the correlators (see in particular the results of [24–28]). This formalism implies that the 3-point correlators involving two protected operators and a non-protected one are completely determined by the structure constants of the highest weight states of each multiplet. From this point of view, the conjecture on the $U(1)_Y$ selection rule of [21] just follows from the form of the possible superspace invariants.

Our results show that, in explicit perturbative gauge theory computations, all the constraints mentioned above are fulfilled only after taking into account the solution of the mixing problem discussed in [19]. For instance, the cancellation occurring in the possibly $U(1)_Y$ violating 3-point correlators with one non-BPS and two half-BPS states are less trivial than suggested in [21]. The leading order quantum corrections from the Feynman diagrams with the insertion of one Yukawa coupling do not vanish for symmetry reason because of the presence of the “phase” factor in the definition of the non-BPS state. However, we show that this contribution is precisely canceled by new contributions coming from the mixing discussed in [19]. In other words the mixing coefficients determined by checking that the non-BPS state has the expected superconformal transformations ensure the cancellation of the correlators that would violate the $U(1)_Y$ selection rule! This shows the necessity of using the correct form of the operators even for those special correlators that are expected to vanish because of some symmetry arguments. Of course the same operators should be used to compute the structure constants that are not constrained by symmetries and we show in one example that the mixing discussed in [19] contributes in a non-trivial way to the final result. We expect that a similar contribution is present also at order $\mathcal{O}(\lambda')$ for the correlators (with the singlet and antisymmetric operators) computed in [16].

Of course, it is very interesting to study the interaction between one non-BPS and two BPS states on the string side of the AdS/CFT correspondence and see whether the constraints discussed above are satisfied also in the string description. As already mentioned, currently the only concrete way to perform this type of test at strong coupling is to focus on the BMN limit. For instance, the cubic Hamiltonian does preserve the $U(1)_Y$ charge in the interaction among three supergravity states [15]. Here we discuss some interactions involving two supergravity and one string states. Again the mixing discussed in [19] plays a crucial role and provides necessary terms to cancel contributions that are prohibited by the superconformal Ward identities or by the $U(1)_Y$ selection rule. However, we will see

specific examples of 3-string amplitudes where these cancellations are not complete and some unwanted terms survive. Thus the BMN 3-string vertex does not seem to satisfy completely all the constraints that we checked at the level of perturbative gauge theory. Another possible way to test the $U(1)_Y$ selection rule at strong coupling is to study the string corrections to the AdS amplitudes with four BPS state. Since in the intermediate channel all non-BPS states are exchanged, a $U(1)_Y$ violating amplitude of this type implies the existence of 3-point correlators that do not satisfy the conjectured selection rule. At the best of our knowledge this kind of checks have not been performed yet in the literature and we will not discuss any explicit example in this paper. However, recent results on the IIB string effective action [29] provide some of the necessary ingredients for the computation of the string corrections to the supergravity amplitudes. Also in this case, it is not clear that the selection rules [20, 21] are preserved away from the strict supergravity limit since the action obtained in [29, 30] contains at least one $U(1)_Y$ violating term. Certainly further analysis is necessary to see whether it is possible to modify or interpret the string results discussed in this paper in a way that is compatible with all the constraints that are so well supported by the perturbative gauge theory analysis.

The paper is organised as follows. In section 2 we discuss the structure of the BMN-like multiplet with two impurities. By using the method introduced in [19] we resolve the operator mixing for the primary state up to order g^2 . Then we derive the form of the level three and level four descendants that we will need in the calculation of the three point correlators of the following sections. In section 3 we illustrate the importance of the subleading terms of the aforementioned states by focusing on some correlators which are bound to be zero either by the supersymmetric Ward identities and/or by the $U(1)_Y$ conservation rule. Were these terms not present in the states one would get a non-zero result for these three-point functions. The resolution of the mixing up to order g^2 allows one to calculate the complete order λ structure constants for any three-point function involving non-BPS states with two impurities. In section 4 we consider an example of a non-trivial three-point function between the primary state and two BPS operators in which the structure coefficient receives a g^2 contribution originating from the subleading term of the primary which has vector impurities. In section 5, we discuss some example of 3-string amplitudes in the PP-wave limit of the $AdS_5 \times S^5$ type IIB string theory. Firstly, we discuss the form of the string states dual to the operators of the long multiplet introduced in section 2. Then, we consider the string amplitudes involving two BPS and one string state and evaluate the PP-wave cubic Hamiltonian in some explicit examples. Finally, in section 6 we comment on these results and discuss their connection to other recent developments in the literature.

2 Operators

Gauge invariant operators in $\mathcal{N} = 4$ SYM¹ are classified according to the representation of the superconformal group $PSU(2, 2|4)$ they belong to. Each representation consists in a multiplet which is generated by the action of the supersymmetry (SUSY) and conformal

¹Throughout the paper, we stick to the conventions in appendix A of [19].

charges on a primary operator. For BPS representations some of the (non-conformal) supersymmetry charges vanish when they act on the superconformal primary. The half BPS highest weight states (HWS) \mathcal{O}_0^J are the operators of free conformal dimension $\Delta^{(0)} = J$ transforming in the $[0, J, 0]$ representation of the $SU(4)_R$ R -symmetry group². The short multiplet is therefore obtained by acting on \mathcal{O}_0^J with the eight supercharges that do not commute with \mathcal{O}_0^J , while the superconformal charges behave as lowering operators. The full $PSU(2, 2|4)$ supermultiplet is obtained via the action of the conformal generators.

In the non-BPS sector we will consider, as highest weight operators, the set of $SO(4) \times SO(4)$ singlets with two impurities. These operators have classical conformal dimension $\Delta^{(0)} = J + 2$, where J is the charge under a $U(1) \subset SO(6)$, and belong to the $[0, J, 0]$ representation of the $SU(4)_R$. Their form was first studied at the classical level and at finite J in [18], while their mixing at the quantum level was discussed in [19]. In [18] it was shown that, for each value of J , we have $E[\frac{J+1}{2}]$ true eigenstates of the planar one-loop scaling dimension. They are labelled by an index n , $0 < n < \frac{J+3}{2}$. Their explicit form up to order g^2 is:

$$\begin{aligned} \mathcal{O}_n^J = & \sqrt{\frac{N_0^{-J-2}}{(J+3)}} \mathcal{Z} \sum_{i=1}^3 \sum_{p=0}^J \cos \frac{\pi n(2p+3)}{J+3} \text{Tr}[Z_i Z^p \bar{Z}_i Z^{J-p}] \\ & + \frac{g\sqrt{N}}{4\pi} \sin \frac{\pi n}{J+3} \sqrt{\frac{N_0^{-J-1}}{(J+3)}} \sum_{p=0}^{J-1} \sin \frac{\pi n(2p+4)}{J+3} \text{Tr}[\psi^{1\alpha} Z^p \psi_{\alpha}^2 Z^{J-1-p}] \\ & - \frac{g\sqrt{N}}{4\pi} \sin \frac{\pi n}{J+3} \sqrt{\frac{N_0^{-J-1}}{(J+3)}} \sum_{p=0}^{J-1} \sin \frac{\pi n(2p+4)}{J+3} \text{Tr}[\bar{\psi}_{3\dot{\alpha}} Z^p \bar{\psi}_{\dot{\alpha}}^4 Z^{J-1-p}] \\ & + \frac{g^2 N}{16\pi^2} \sin^2 \frac{\pi n}{J+3} \sqrt{\frac{N_0^{-J}}{(J+3)}} \sum_{p=0}^{J-2} \cos \frac{\pi n(2p+5)}{J+3} \text{Tr}[D_{\mu} Z Z^p D^{\mu} Z Z^{J-p-2}] + \mathcal{O}(g^3) . \end{aligned} \tag{2.1}$$

Here $N_0 = \frac{N}{8\pi^2}$, and \mathcal{Z} represents the scheme-dependent wave function renormalisation, which will not play any role in our subsequent computation (see [31] for an explicit evaluation of \mathcal{Z} in dimensional regularisation). In [19] we computed the coefficient weighting the mixing with fermionic impurities in (2.1) by demanding that \mathcal{O}_n^J is annihilated by the full set of superconformal charges up to order g . Analogously, here we have computed the coefficient in front of the term with vector impurities by demanding that the tree-level action of \bar{S}_1 on the last line in (2.1) against the order- g^2 contributions we get acting with the same charge on the terms with fermionic impurities. Since $\bar{S}_1(Z)(0) = 0$, the first is totally encoded by the tree-level action of $\bar{S}_1^{\dot{\alpha}}$ on $D_{\mu} Z$:

$$\bar{S}_1^{\dot{\alpha}} \not{D}_{\alpha\dot{\beta}} Z = 2\sqrt{2} \psi_{\alpha}^2 \delta_{\dot{\beta}}^{\dot{\alpha}}. \tag{2.2}$$

On the other hand, a direct computation shows that the second type of contributions follows from the order- g action of \bar{S}_1 on the pairs with Z and ψ^1 :

$$\bar{S}_1^{\dot{\alpha}}(\psi_{\alpha}^1 Z) = -\bar{S}_1^{\dot{\alpha}}(Z \psi_{\alpha}^1) = -\frac{gN}{8\pi^2} \bar{\sigma}^{\mu\dot{\alpha}}_{\alpha} D_{\mu} Z. \tag{2.3}$$

²In this paper we work at the planar level and so we neglect the mixing with multitrace operators.

To obtain eq. (2.2) we rewrote $\mathbb{D}_{\alpha\dot{\alpha}}Z = \frac{1}{\sqrt{2}}Q_{4\alpha}\bar{\psi}_{3\dot{\alpha}}$, we anticommutated Q and \bar{S} and then we used eq. (3.13) of [19]. Eq. (2.3) has been obtained by rewriting $\psi^1 = -\frac{i}{\sqrt{2}}Q_3Z_2$, then anticommuting the charges acting on the pair of scalar fields. The action of S_1^α on the pair (Z_2Z) at order g can be read from eq. (3.2) of [19].

This approach circumvents the technically hard issue of diagonalising the 2-point functions up to higher orders in perturbation theory. In fact, despite appearing at order g and g^2 , the subleading mixing terms in (2.1) will start contributing to the 2-point functions only at order greater than the separation between the two impurities.³ As predicted in [32], all the corrections compatible with the $SU(4)_R$ and Lorentz symmetries appear in the form of the HWS, while what could not have been predicted easily from the diagonalisation of the 2-point functions is that the order g and g^2 mixing involves terms where the impurities are separated by an arbitrary number of Z 's. In the next sections we will show that these subleading terms in (2.1) are crucial in the computation of the structure. This approach can of course be pursued to higher orders in perturbation theory, once the corrections to the supercharges are known.

One gets the full long multiplet acting with all sixteen (non-conformal) supercharges on the highest weight state in (2.1). For the sake of simplicity, we will consider the descendants of \mathcal{O}_n^J whose number of impurities is fixed to $\Delta^{(0)} - J = 2$. They are obtained by acting on (2.1) with the supersymmetry transformations that leave Z invariant. Besides the usual transformation under $PSU(2, 2|4)$, we can introduce an additional quantum number u_Y by assigning $u_Y = +1$ and $u_Y = -1$ to $Q_{A\alpha}$ and $\bar{Q}^{A\dot{\alpha}}$ respectively, while \bar{S} has the same charge as Q . Then, according to the superconformal algebra (see for instance [33]), all the bosonic generators have zero $U(1)_Y$ charge. Although the corresponding $U(1)_Y$ transformation is an exact symmetry of the theory only at $\lambda = 0$ and $\lambda = \infty$, it is possible to define a u_Y charge of each highest weight state. Then the $U(1)_Y$ charge of any operator in the multiplet is obtained by summing the charges of the supersymmetry transformations used in its derivation [21]. In the following we will focus on the operators obtained by acting with supercharges with the same chirality which thus have a non-zero charge under $U(1)_Y$. In particular, setting the charge of the HWS to zero, the level-three operator $^{[3]}\mathcal{O}_{n,\alpha}^{J,2\bar{Z}_1} = Q_{4\alpha}(Q_3)^2\mathcal{O}_n^{J-1}$ and the level-four operator $^{[4]}\mathcal{O}_n^J = (Q_3)^2(Q_4)^2\mathcal{O}_n^{J-1}$ will have $U(1)_Y$ charge $u_y = 3$ and $u_y = 4$ respectively. In order to get their expression up to order g in perturbation theory, we apply again the approach of [19]. The first state is

$$\begin{aligned}
 ^{[3]}\mathcal{O}_{n,\alpha}^J \propto & \sum_{p=0}^J \sin \frac{\pi n(2p+2)}{J+2} \text{Tr}[\psi_\alpha^2 Z^p \bar{Z}_1 Z^{J-p} - \psi_\alpha^1 Z^p \bar{Z}_2 Z^{J-p}] + \\
 & + \frac{igN}{8\sqrt{2}\pi^2} \sin \frac{\pi n}{J+2} \sum_{p=0}^{J-1} \cos \frac{\pi n(2p+3)}{J+2} \text{Tr}[\mathbb{D}_{\alpha\dot{\alpha}} Z Z^p \bar{\psi}_3^{\dot{\alpha}} Z^{J-p-1}]. \quad (2.4)
 \end{aligned}$$

We have obtained the coefficient weighting the mixing among the different kinds of impurities by requiring that the state in (2.4) is annihilated by the superconformal charges

³For example, the first term in the sum involving the fermionic impurities will start contributing to the anomalous dimension at two loops.

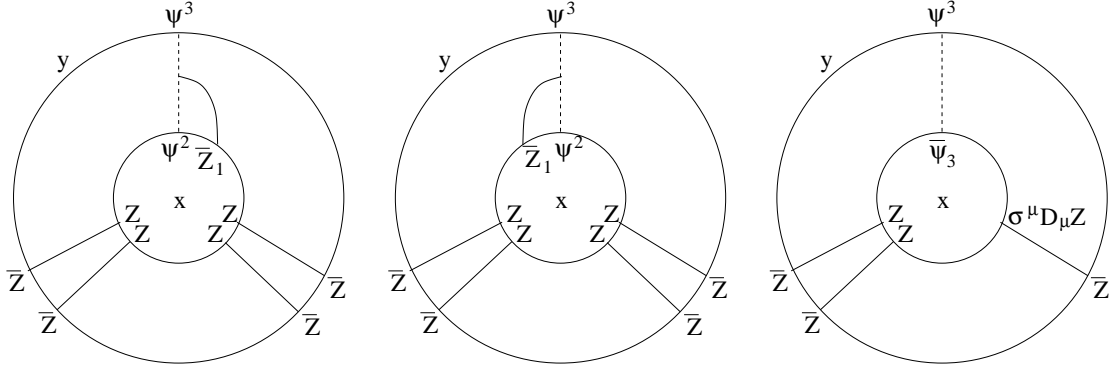

Figure 1. Diagrams contributing to the correlator between the level-three non-BPS state in (2.4) and $\text{Tr}[\psi_3 \bar{Z}^J]$. The first two diagrams comes from the contraction of the leading term containing $\text{Tr}[\psi_\alpha^2 Z^p \bar{Z}_1 Z^{J-p}]$. The term with $\text{Tr}[\psi_\alpha^1 Z^p \bar{Z}_2 Z^{J-p}]$ contributes with two identical diagrams which just double the result of those shown here. The third diagram is the one contributing to the free contraction between the BPS state and the subleading term of the long one

$S^{A=1,2}$ and, because of $\{\bar{S}_A, Q_B\} = 0$, by all the \bar{S}_A , with $A = 1, \dots, 4$, up to order g . This holds trivially at order zero, while the terms of order g may get contributions both from the one-loop action of the relevant superconformal charges on the leading term of (2.4) and from the tree-level action of the various \bar{S} on the subleading one. In particular, if we focus on the \bar{S}_1^α , it is immediate to notice that the one-loop action on the pairs involving Z and \bar{Z}_1 ,

$$\bar{S}_1^\alpha(Z \bar{Z}_1) = -\bar{S}_1^\alpha(\bar{Z}_1 Z) = \frac{igN}{8\pi^2} \bar{\psi}_3^\alpha, \quad (2.5)$$

is compensated by its classical action on the derivative impurity in the subleading term in (2.2), $\bar{S}_1^\alpha \mathcal{D}_{\alpha\beta} Z = 2\sqrt{2} \psi_\alpha^2 \delta_\beta^\alpha$.

A crucial check on the mixing coefficient in (2.4) is the orthogonality between the level-three operator and any BPS state. We can check this point explicitly for the case of a level one supergravity state $\text{Tr}[\bar{\psi}_3^\beta Z^J]$. The diagrams contributing to the two-point function $\langle \text{Tr}[\psi_\beta^3 \bar{Z}^J](x)^{[3]} \mathcal{O}_\alpha^J(y) \rangle$ are listed in figure 1. The four diagrams contributing to the contraction between the BPS operator and the leading term of $^{[3]} \mathcal{O}_{n,\alpha}^J$ sum up to:

$$A_2^{(1)} = ig \frac{N^{J+2}}{\sqrt{2} 2^{J-1}} \sin \frac{2\pi n}{J+2} \Delta_{xy}^J \epsilon^{\dot{\alpha}\dot{\beta}} \sigma_{\alpha\dot{\alpha}}^\nu \sigma_{\beta\dot{\beta}}^\mu \int d^4 z \Delta_{zy} \partial_\nu^z \Delta_{zy} \partial_\mu^z \Delta_{zx}, \quad (2.6)$$

where the relevant Yukawa coupling takes the form $ig4\sqrt{2} \epsilon_{\dot{\alpha}\dot{\beta}} \int d^4 z \text{Tr}[\bar{\psi}_A^{\dot{\alpha}} \bar{\psi}_B^{\dot{\beta}} \Phi^{AB}]$. After rewriting $\Delta_{zy} \partial_\nu^z \Delta_{zy} = \frac{1}{2} \partial_\nu^z \Delta_{zy}^2$ and integrating by parts, we can exploit the symmetry of the remaining integral to write:

$$\epsilon^{\dot{\alpha}\dot{\beta}} \sigma_{\alpha\dot{\alpha}}^\nu \sigma_{\beta\dot{\beta}}^\mu \int d^4 z \Delta_{zy} \partial_\nu^z \Delta_{zy} \partial_\mu^z \Delta_{zx} = -\epsilon_{\alpha\beta} \frac{i}{2} \Delta_{xy}^2. \quad (2.7)$$

Then we obtain:

$$A_2^{(1)} = \frac{gN^{J+2}}{2^J \sqrt{2}} \sin \frac{2\pi n}{J+2} \epsilon_{\alpha\beta} \Delta^{J+2}(x). \quad (2.8)$$

On the other hand, the free contractions between the supergravity state and the sub-leading term of the long operator yield

$$A_2^{(2)} = \frac{g_{\text{YM}} N}{8\sqrt{2}\pi^2} \left(\frac{N}{2}\right)^{J+1} \sin \frac{\pi n}{J+2} \left(\sum_{p=0}^{J-1} \cos \frac{\pi n(2p+3)}{J+2} \right) \Delta_{xy}^{J-1} \epsilon^{\dot{\alpha}\dot{\beta}} \sigma_{\alpha\dot{\alpha}}^\mu \sigma_{\beta\dot{\beta}}^\nu \partial_\mu^x \Delta_{xy} \partial_\nu^x \Delta(x)_{xy}. \quad (2.9)$$

By rewriting

$$\sigma_{\alpha\dot{\alpha}}^\mu \epsilon^{\dot{\alpha}\dot{\beta}} \sigma_{\beta\dot{\beta}}^\nu \partial_\mu^x \Delta_{xy} \partial_\nu^x \Delta_{xy} = 16\pi^2 \Delta_{xy}^3 \epsilon_{\alpha\beta} \quad (2.10)$$

and

$$\sum_{p=0}^{J-1} \cos \frac{\pi n(2p+3)}{J+2} = -\frac{\sin \frac{2\pi n}{J+2}}{\sin \frac{\pi n}{J+2}}, \quad (2.11)$$

we notice that the $A_2^{(2)}$ cancels exactly the $A_2^{(1)}$ and then the two point function we are considering is zero at order g .

The coefficients of the level four state are fixed in a similar way: we require that it is annihilated by the supersymmetry charges Q_3 and Q_4 , by the superconformal generators S^1 and S^2 and, since $\{\bar{S}^A, Q_B\} = 0$, by all the \bar{S}^A , $A = 1, \dots, 4$. We get, up to order g ,

$$\begin{aligned} [4]\mathcal{O}_n^J &\propto \sum_{p=0}^J \sin \frac{\pi n(2p+2)}{J+2} \text{Tr}[\psi^{1\alpha} Z^p \psi_\alpha^2 Z^{J-p}] + \\ &- 2\sqrt{2}g \sin \frac{\pi n}{J+2} \sum_{p=0}^{J+1} \cos \frac{\pi n(2p+1)}{J+2} \text{Tr}[\Phi_{AB} Z^p \Phi^{AB} Z^{J-p+1}] + \\ &+ \frac{gN}{8\sqrt{2}\pi^2} \sin \frac{\pi n}{J+2} \sum_{p=0}^{J-1} \cos \frac{\pi n(2p+3)}{J+2} \text{Tr}[D_\mu Z Z^p D^\mu Z Z^{J-p-1}] + \mathcal{O}(g^2). \end{aligned} \quad (2.12)$$

More explicitly, we fixed the coefficient of the term with flavour impurities by requiring that the tree-level action of e.g. Q_3 on it cancels again the order- g action of Q_3 on the leading term (notice that the order- g action of Q_3 on the fermions is totally encoded by the classical supersymmetry variations, see for instance appendix A of [19]). The coefficient of the term with derivative impurities has been fixed acting once again with \bar{S}_1 at tree-level on the third line of (2.12) and at order g on its leading term. For the sake of simplicity, we dropped the overall normalisation in equations (2.12) and (2.4).

A couple of comments follows. First, notice that the state in (2.1) gives the correct eigenvalue of the dilatation operator up to order g^4 . The subleading terms appearing in the HWS are the only ones allowed by the $SU(4)_R$ and Lorentz symmetries. Thus, further quantum corrections will appear only as higher order modifications of the mixing coefficients. Among these, the first is a g^3 term modifying the mixing with fermions. Since there is no overlap between the leading and the first subleading term in (2.1) up to order g^3 [19], it will start contributing only from three loops on. Second, one can obtain the order g corrections in (2.1) from the asymptotic S-matrix approach of [34]. The eigenstate of the dilatation operator should be of the form of eq. (3.11) of [34], where one should consider as the incoming asymptotic state a linear combination of two terms, one with two

bosonic impurities and one with two fermionic ones. The relative coefficient between these two terms is fixed by requiring that the full state is periodic. Then by using the S-matrix of [34], we checked that the eigenstates agree with the asymptotic behaviour (2.1). However, this approach does not capture the non-asymptotic terms in the state in [34]. These terms can be determined either by diagonalising the Hamiltonian up to the appropriate order or by means of the method advocated in [19].

3 Correlators

The aim of this section is to investigate in explicit examples the role played by the operator mixing in the correlators involving one non-BPS operator and two half-BPS ones. These correlators were studied in [21], with emphasis on the constraints that their total $U(1)_Y$ charge puts on the related structure constants. In [20] it was conjectured that, based on AdS/CFT correspondence, three and four-point correlators of half-BPS operators respect a $U(1)_Y$ conservation selection rule. This conjecture was extended to the 3-point correlators with a single non-BPS state in [21], where some explicit examples of correlators involving a descendant of the Konishi operator were discussed.

In the following sections, we will consider explicitly correlators whose total $U(1)_Y$ charge is different from zero, and we will show that the role played by the subleading terms in (2.1) is crucial for preserving the $U(1)_Y$ selection rule. It is in fact important to stress that the operators in (2.1) differ from the operators used in [21] not only for the presence of the subleading terms, but also for the cos and sin factors weighting the addends in the leading term. The non-BPS operators in [21] are totally symmetric combination of scalars with a given number of traces. However, unlike \mathcal{O}_n^J , such operators are not eigenstates of the planar anomalous dimension at one loop. Because of the cosine function weighting the sum in the leading term of \mathcal{O}_n^J , some of the arguments used in [21] to check the selection rule are no longer valid. In section 3.1 we consider an explicit example in which the selection rule is restored once the contribution of the subleading terms of the long operator is taken into account. In section 3.2 we analyse a 3-point correlator where the mixing plays a crucial role in realizing the constraints following directly from the supersymmetric Ward Identities.

3.1 $U(1)_Y$ violating correlators

In this section, we consider two cases of $U(1)_Y$ -violating correlators: the first case involves the non-BPS HWS and two antisymmetric level-two BPS descendants, and the second correlator is between two BPS HWS and the non-BPS level-four descendent (2.12).

To be explicit, let us focus on the following correlator:

$$\langle \bar{Q}_{\dot{\alpha}}^1 \bar{Q}^{2\dot{\alpha}} \bar{O}_0^{J_1+2}(x_1) \bar{Q}_{\dot{\beta}}^1 \bar{Q}^{2\dot{\beta}} \bar{O}_0^{J_2+2}(x_2) \mathcal{O}_n^{J_3}(x_3) \rangle, \quad (3.1)$$

with $J_3 = J_1 + J_2 + 2$. The operators in x_1 and x_2 are two level-two BPS we get acting with $\bar{Q}^{1\dot{\alpha}}$ and $\bar{Q}^{2\dot{\beta}}$ on the operators $\text{Tr}[\bar{Z}^{J_i+2}]$, $i = 1, 2$. In particular, we will focus on the

singlet under the spacetime $SO(4)_{st}$:

$$\bar{Q}_{\dot{\alpha}}^1 \bar{Q}^{2\dot{\alpha}} \bar{O}_0^{J+2} \propto \sum_{k=0}^J \text{Tr}[\bar{\psi}_{2\dot{\alpha}} \bar{Z}^k \bar{\psi}_1^{\dot{\alpha}} \bar{Z}^{J-k}] - g\sqrt{2} (\text{Tr}[[\bar{Z}_1, Z_1] \bar{Z}^{J+1}] + \text{Tr}[[Z_2, \bar{Z}_2] \bar{Z}^{J+1}]). \quad (3.2)$$

For the sake of simplicity, let us drop the overall normalisation in eq. (2.1). According to [22], any operator belonging to the non-BPS multiplet generated by the HWS in (2.1) does not appear in the OPE between any two BPS states belonging to the multiplets generated by $\text{Tr}[\bar{Z}^{J_i+2}]$, $i = 1, 2$ respectively. Furthermore, the three-point function (3.1) has total $U(1)_Y$ charge $u_Y = -2$, hence violates the $U(1)_Y$ -conservation selection rule.

For notational purpose, let us split each operator into a leading plus subleading term. Then, the non-BPS operator can be written as $L_n + gS_n$, while the two BPS ones will be denoted as $L_0^{1(2)} + gS_0^{1(2)}$. The first non trivial contributions to (3.1) are of order g^2 and originate from three kinds of correlators, respectively involving the leading terms of the three operators, two leading terms and a subleading one, and one leading and two subleading ones. Notice that the non-BPS operator has additional subleading terms, of the type $g^2 \text{Tr}[D_\mu Z Z^p D^\mu Z Z^{J-2-p}]$, which can potentially contribute at order g^2 to correlations functions involving the non-BPS primary state. However, this is not the case in (3.1) because such term cannot be freely contracted with the leading terms of the BPS operators. The contributions $\langle L_0^1 L_0^2 L_n \rangle$, $\langle S_0^1 L_0^2 S_n \rangle$ and $\langle L_0^1 S_0^2 S_n \rangle$ follow only from diagrams involving self-contractions and are, consequently, zero. Among the remaining contributions, let us focus on the contractions involving the leading term of the non-BPS operator. The two correlators $\langle S_0^1 L_0^2 L_n \rangle$ and $\langle L_0^1 S_0^2 L_n \rangle$ are also zero at order $\mathcal{O}(g^2)$. In fact, the allowed diagrams come from the inclusion of a Yukawa coupling whose fermions can only be contracted with the two fermions belonging to one of the BPS operators. The Yukawa coupling is antisymmetric in the two flavour indices, while the short operator is symmetric, therefore these diagrams are zero. This is just a rephrasing of the colour $d \cdot f$ -contraction rule envisaged in [21], which was the cause of the vanishing of the full correlator.

However, here the situation is different, since the leading term of the non-BPS HWS is not fully symmetric in the colour indices. An explicit computation shows that:

$$\langle S_0^1 S_0^2 L_n \rangle = \frac{g^2 N^{J_3+2}}{2^{J_3-1}} \left(\cos \frac{3\pi n}{J_3+3} - \cos \frac{\pi n(2J_1+5)}{J_3+3} \right) \Delta_{x_1 x_2} \Delta_{x_1 x_3}^{J_1+2} \Delta_{x_2 x_3}^{J_2+2}. \quad (3.3)$$

Let us now focus on the computation of the term of the correlator including the sub-leading term in the HWS, namely $\langle L_0^1 L_0^2 S_n \rangle$. We have four diagrams contributing: two of them are shown in figure 2, while the others differ from the first ones only for the exchanged of the operators labelled as 1 and 2, and thus they yield the same result of the diagrams in figure 2. Focusing on the diagram on the left, we get:

$$A_1 = \delta_{p, k_1+k_2} \frac{g^2 \sqrt{2}}{(4\pi^2)^4} \left(\frac{N}{2} \right)^{J_3+1} \Delta_{x_1 x_3}^{J_1} \Delta_{x_2 x_3}^{J_2} \bar{\sigma}^{\mu\dot{\alpha}\alpha} \sigma_{\alpha\dot{\beta}}^\nu \bar{\sigma}^{\rho\dot{\beta}\beta} \sigma_{\beta\dot{\alpha}}^\lambda \frac{x_{13\mu} x_{13\lambda} x_{23\nu} x_{23\rho}}{x_{12}^2 x_{13}^6 x_{23}^2}, \quad (3.4)$$

where the Yukawa coupling involved is: $-i2\sqrt{2}\epsilon^{\alpha\beta} \int d^4 z \text{Tr}[\psi_\alpha^1 \psi_\beta^2 \bar{Z}]$. We have also used $\int d^4 z \Delta_{x_3 z} \partial_\mu^{x_1} \Delta_{x_1 z} \partial_\nu^{x_2} \Delta_{x_2 z} = \frac{i}{(4\pi^2)^2} \frac{x_{13\mu} x_{23\nu}}{x_{12}^2 x_{13}^2 x_{23}^2}$ (see appendix B of [19]).

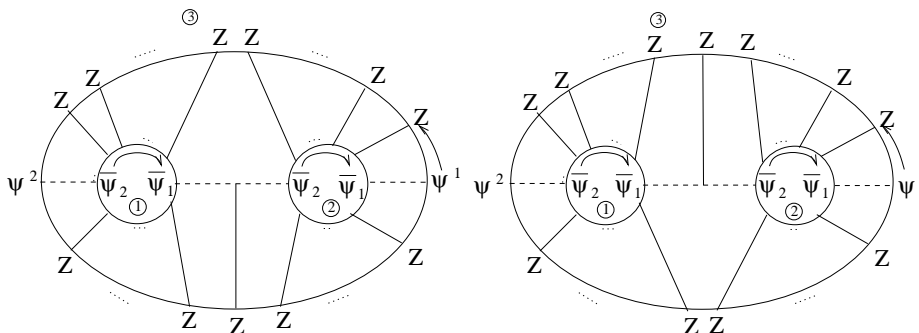

Figure 2. Diagrams contributing to the $\langle L_0^1 L_0^2 S_n \rangle$ part of (3.1). There are two additional diagrams where the role of $\bar{\psi}_1$ and $\bar{\psi}_2$ in each of the BPS operators are exchanged.

The diagram on the right of figure 2 differs from the first one by an overall minus sign, due to the different orientation of the Yukawa coupling, and for the different identification δ_{p, k_1+k_2+1} . Rewriting $\bar{\sigma}^{\mu\dot{\alpha}\alpha}\sigma_{\alpha\dot{\beta}}^{\nu}\bar{\sigma}^{\rho\dot{\beta}\beta}\sigma_{\beta\dot{\alpha}}^{\lambda} = 2\eta^{\mu\lambda}\eta^{\nu\rho} + \dots$, where the dots stand for terms which are antisymmetric in the pairs (μ, λ) and (ν, ρ) and which therefore we can discard, we write the full correlator as:

$$\langle L_0^1 L_0^2 S_n \rangle = -\sin \frac{\pi n}{J_3 + 3} \sum_{k_1, k_2=0}^{J_1, J_2} \left(\sin \frac{2\pi n(k_1 + k_2 + 2)}{J_3 + 3} - \sin \frac{2\pi n(k_1 + k_2 + 3)}{J_3 + 3} \right) \times \frac{g^2 N^{J_3+2}}{2^{J_3-1}} \Delta_{x_1 x_2} \Delta_{x_1 x_3}^{J_1+2} \Delta_{x_2 x_3}^{J_2+2} \quad (3.5)$$

Redefining $k_2 + 1 \rightarrow k_2$ in the second term, we can rewrite the double sum as

$$2 \sum_{k_1=0}^{J_1} \sin \frac{2\pi n(k_1 + 2)}{J_3 + 3} = \frac{1}{\sin \frac{\pi n}{J_3+3}} \left(\cos \frac{3\pi n}{J_3 + 3} - \cos \frac{\pi n(2J_1 + 5)}{J_3 + 3} \right). \quad (3.6)$$

Therefore we get

$$\langle L_0^1 L_0^2 S_n \rangle = -\frac{g^2 N^{J_3+2}}{2^{J_3-1}} \left(\cos \frac{3\pi n}{J_3 + 3} - \cos \frac{\pi n(2J_1 + 5)}{J_3 + 3} \right) \Delta_{x_1 x_2} \Delta_{x_1 x_3}^{J_1+2} \Delta_{x_2 x_3}^{J_2+2}, \quad (3.7)$$

which exactly cancels the result of (3.3).

This kind of cancellation is somehow reminiscent of the effect of a mixing between scalar and fermions which has been invoked in [21] to protect the $U(1)_Y$ bonus symmetry in correlators involving descendants of the Konishi operator. However, here the pattern is quite different. This becomes particularly transparent when we consider examples of correlators involving the supersymmetry descendants in the non-BPS multiplet. In this case, the subleading terms in the operator include both the effects of the quantum corrections to the supersymmetry generators and the mixing due to the generalised Konishi anomaly, which both contribute to obtain the correct value of the structure constants.

Explicitly, let us focus on the level-four operator we get by acting on the non-BPS HWS with the four charges with positive chirality and let us consider the 3-point function:

$$\langle \mathcal{O}_0^{J_1, \bar{Z}_1 \bar{Z}_2}(x_1) \mathcal{O}_0^{J_2, Z_1 Z_2}(x_2) [^4] \bar{\mathcal{O}}_n^{J_3}(x_3) \rangle, \quad (3.8)$$

with $J_3 = J_1 + J_2 - 1$. It involves the conjugate of the non-BPS operator in (2.12) and the two BPS states:

$$\mathcal{O}_0^{J_1, \bar{Z}_1 \bar{Z}_2} = \sum_{k_1=0}^{J_1} \text{Tr}[\bar{Z}_1 Z^{k_1} \bar{Z}_2 Z^{J_1-k_1}], \quad (3.9a)$$

$$\mathcal{O}_0^{J_2, Z_1 Z_2} = \sum_{k_2=0}^{J_2} \text{Tr}[Z_1 Z^{k_2} Z_2 Z^{J_2-k_2}]. \quad (3.9b)$$

Since the operators participating in this correlator are Lorentz scalars, conformal invariance fixes its spacetime form to be:

$$\frac{1}{|x_{12}|^{\Delta_1+\Delta_2-\Delta_3} |x_{13}|^{\Delta_1+\Delta_3-\Delta_2} |x_{23}|^{\Delta_2+\Delta_3-\Delta_1}} \quad (3.10)$$

Furthermore, the conformal dimensions of the operators are not corrected at order g , thus $\Delta_1 + \Delta_2 - \Delta_3 = 2$, $\Delta_1 + \Delta_3 - \Delta_2 = 2(J_1 + 1)$ and $\Delta_2 + \Delta_3 - \Delta_1 = 2(J_2 + 1)$.

The first non-trivial contributions to (3.8) come at order g . There are three classes of diagrams. In the first one the leading term of the non-BPS operator is contracted to the two BPS states through a Yukawa. The relevant diagrams are shown on the left of figure 3. The second class of diagrams involves the subleading term of the non-BPS operator and is shown on the right of figure 3. Finally, the third contribution originates from the free contractions of the subleading term of the long operator which has vector impurities with the two BPS operators. The corresponding diagrams are depicted in figure 4.

In the first case, we have planar diagrams for $k_1 = 0, k_2 = J_2$ and $k_1 = J_1, k_2 = 0$. In both cases, the contraction of the two fermions in the leading term of the long operators with the Yukawa coupling requires either $p = 0$ or $p = J_3$. The contributions coming from diagrams resulting from these two different value of the sum parameter p sum up, because the relative minus sign coming from the different orientation of the Yukawa coupling is actually compensated by the different phase factor since $\sin \frac{\pi n(2J_3+2)}{J_3+2} = -\sin \frac{2\pi n}{J_3+2}$. In both cases, $p = 0$ and $p = J_3$, it is then possible to contract the scalar in the Yukawa coupling with either any of the Z in x_1 or any in x_2 . Taking into account all the multiplicity factors, we have:

$$\begin{aligned} A_3^{(L)} = & -i\sqrt{2} \frac{gN^{J_3+3}}{2^{J_3+1}} \Delta_{x_1 x_2}^2 \Delta_{x_1 x_3}^{J_1-1} \Delta_{x_2 x_3}^{J_2-1} \times \\ & \times \left(J_1 \Delta_{x_2 x_3} \int d^4 z \Delta_{x_1 z} \partial_\mu^{(x_3)} \Delta_{x_3 z} \partial^{\mu(x_3)} \Delta_{x_3 z} \right. \\ & \left. + J_2 \Delta_{x_1 x_3} \int d^4 z \Delta_{x_2 z} \partial_\mu^{(x_3)} \Delta_{x_3 z} \partial^{\mu(x_3)} \Delta_{x_3 z} \right) \end{aligned} \quad (3.11)$$

The integrals in the last equation can be computed for a spacetime dimension $d < 2$ and the result is analytically continued to $d = 4$. We get

$$\int d^4 z \Delta_{x_i z} \partial_\mu^{(x_3)} \Delta_{x_3 z} \partial^{\mu(x_3)} \Delta_{x_3 z} = -\frac{i}{2} \Delta_{x_1 x_3}^2,$$

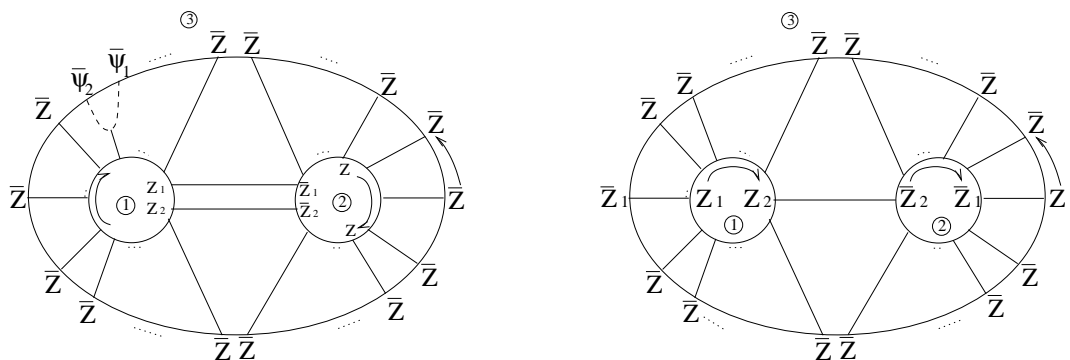

Figure 3. On the left, the diagram contributing to the contraction of the leading term of the level-four long state with the two BPS and a Yukawa coupling, for $k_1 = J_1$, $k_2 = 0$, $p = 0$. On the right, the planar diagram contributing to the tree-level contraction of the subleading term with flavour impurities of the level-four long state with two BPS.

so we have

$$A_3^{(L)} = -\frac{gN^{J_3+3}}{2^{J_3+1}\sqrt{2}} \Delta_{x_1x_2}^2 \Delta_{x_1x_3}^{J_1} \Delta_{x_2x_3}^{J_2} (J_1 \Delta_{x_1x_3} + J_2 \Delta_{x_2x_3}). \quad (3.12)$$

Notice that the result above does not take the form dictated by conformal invariance. We will show that this term cancels against an identical one coming from the tree-level contraction of the subleading terms of $^{[4]}\mathcal{O}_n^J$.

Next we consider the contribution coming from the (conjugate of the) second line of (2.12), and let us focus on the term containing $\text{Tr}[\bar{Z}_1 \dots Z_1 \dots]$. The only possible planar tree-level contractions are illustrated by the second diagram in figure 3, which forces the constraint $p = k_1 - k_2 + J_2$. The contribution of the term containing $\text{Tr}[\bar{Z}_2 \dots Z_2 \dots]$ differs only for the constraint, which in this case is $p = k_2 - k_1 + J_1$. However, this is related to the previous one by exchanging $p \rightarrow J_3 - p + 1$ and, since the phase factor involved in this computation, $\cos \frac{\pi n(2p+1)}{J_3+2}$, is symmetric under this exchange, this contribution will just double the result of the diagram in figure 3. The sum over the allowed phases gives:

$$\sum_{k_1=0}^{J_1} \sum_{k_2=0}^{J_2} \cos \frac{\pi n[2(J_2 + k_1 - k_2) + 1]}{J_3 + 2} = \frac{1}{2} \sin^{-2} \frac{\pi n}{J_3 + 2} \left(\cos \frac{\pi n(2J_1 + 1)}{J_3 + 2} - \cos \frac{\pi n}{J_3 + 2} \right), \quad (3.13)$$

and it leads to:

$$A_3^{(SL_f)} = \frac{gN^{J_3+3}}{2^{J_3+2}\sqrt{2}} \sin^{-1} \frac{\pi n}{J_3 + 2} \left(\cos \frac{\pi n}{J_3 + 2} - \cos \frac{\pi n(2J_1 + 1)}{J_3 + 2} \right) \Delta_{x_1x_2} \Delta_{x_1x_3}^{J_1+1} \Delta_{x_2x_3}^{J_2+1}. \quad (3.14)$$

Now let us analyse the contribution to the three-point function coming from the term of the non-BPS operator containing derivative-impurities. We can have planar contractions for $k_1 = 0$, $k_2 = J_2$ and $k_1 = J_1$, $k_2 = 0$, both leading to the same result. On the contrary, the situation associated with the different values of the parameter p , counting the separation between the impurities in the third line of (2.12), is quite different. In fact, for any given value of p , the associated diagram will have different multiplicity if we contract the two

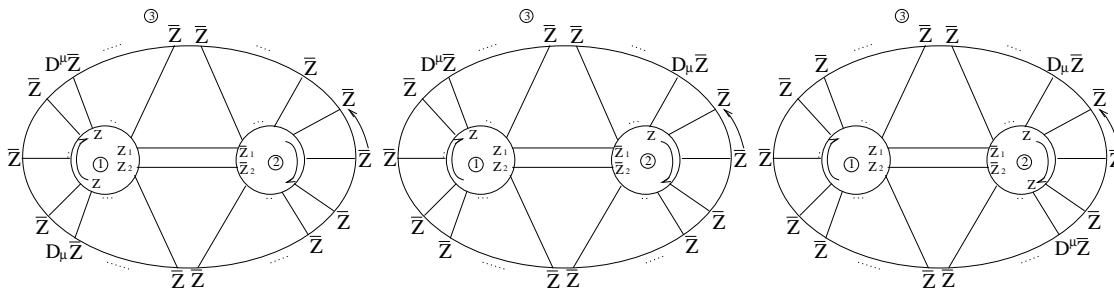

Figure 4. Diagrams originating from the free contractions of the subleading term of the long operator having two vector impurities and the two BPS operators. In the diagram on the left, both impurities of the long state are contracted with the operator sitting at x_1 . In the diagram in the middle, one impurity is contracted with the operator at x_1 and the other with the operator at x_2 . Finally, in the diagram on the right both impurities are contracted with the operator at x_2 .

derivative impurities with two background fields Z in x_1 , one Z in x_1 and one in x_2 , or two Z in x_2 respectively. The three cases are represented in figure 4. Let us analyse each case separately. We can contract both the impurities with scalars in x_1 for $p \in [0, J_1 - 2]$. For any value of p , each diagram comes with a multiplicity factor of $J_1 - p - 1$ (this can be obtained, e.g., by counting the different numbers of \bar{Z} which we can insert on the left of the first impurity which are contracted with scalars in x_1 too - notice that in figure 4 the trace in x_3 runs counter-clock-wise). Since any of these diagrams gives the same spacetime structure, this can be factor out and the sum over the phases gives:

$$\sum_{p=0}^{J_1-2} (J_1 - p - 1) \cos \frac{\pi n(2p+3)}{J_3+2} = \frac{1}{4} \sin^{-2} \frac{\pi n}{J_3+2} \left[\cos \frac{\pi n}{J_3+2} - \cos \frac{\pi n(2J_1+1)}{J_3+2} - 4J_1 \cos \frac{\pi n}{J_3+2} \sin^2 \frac{\pi n}{J_3+2} \right] \quad (3.15)$$

We can further exchange the role of the two impurities. However, this ultimately means that we are redefining $p \rightarrow J_3 - p - 1$ in the double sum in (3.15), and it just doubles its result. Thus, the complete contribution to the correlator coming from the leftmost diagrams in figure 4 is:

$$A_3^{(SL_d1)} = -\frac{N^{J_3+3} g}{2^{J_3+2} \sqrt{2}} \sin^{-1} \frac{\pi n}{J_3+2} \times \left(\cos \frac{\pi n}{J_3+2} - \cos \frac{\pi n(2J_1+1)}{J_3+2} - 2J_1 \cos \frac{\pi n}{J_3+2} \sin \frac{2\pi n}{J_3+2} \right) \Delta_{x_1 x_2}^2 \Delta_{x_1 x_3}^{J_1+1} \Delta_{x_2 x_3}^{J_2} \quad (3.16)$$

where we have already taken into account the mixing coefficient multiplying the trace in (2.12) and we have rewritten $\partial_\mu^{(x_3)} \Delta_{x_1 x_3} \partial^{\mu(x_3)} \Delta_{x_1 x_3} = -16\pi^2 \Delta_{x_1 x_3}^3$. The contribution of the contractions illustrated in the rightmost diagram in figure 4, in which we contract both the derivative impurities with scalars in x_2 , differs from (3.16) just for the exchange

$J_1 \rightarrow J_2$ and $x_1 \rightarrow x_2$:

$$A_3^{(SL_d3)} = -\frac{N^{J_3+3}g}{2^{J_3+2}\sqrt{2}} \sin^{-1} \frac{\pi n}{J_3+2} \times \left(\cos \frac{\pi n}{J_3+2} - \cos \frac{\pi n(2J_2+1)}{J_3+2} - 2J_2 \cos \frac{\pi n}{J_3+2} \sin \frac{2\pi n}{J_3+2} \right) \Delta_{x_1x_2}^2 \Delta_{x_1x_3}^{J_1} \Delta_{x_2x_3}^{J_2+1}. \quad (3.17)$$

The easiest way to compute the multiplicity of the central diagrams in figure 4 is to introduce a further integer k counting the number of \bar{Z} following $D^\mu \bar{Z}$ which are also contracted with a scalar in x_1 . It is then immediate to notice that $k \in [0, J_1 - 1]$ and for any given value of k we have $p \in [k, J_2 + k - 1]$. Again, exchanging the role of the two impurities just give an overall factor of 2, then the multiplicity of the diagrams is taken into account by the double sum:

$$2 \sum_{k=0}^{J_1-1} \sum_{p=k}^{J_2+k-1} \cos \frac{\pi n(2p+3)}{J_3+2} = -\sin^{-2} \frac{\pi n}{J_3+2} \left(\cos \frac{\pi n}{J_3+2} - \cos \frac{\pi n(2J_1+1)}{J_3+2} \right). \quad (3.18)$$

Then we have:

$$A_3^{(SL_d2)} = \frac{gN^{J_3+3}}{2^{J_3+2}\sqrt{2}} \sin^{-1} \frac{\pi n}{J_3+2} \left(\cos \frac{\pi n}{J_3+2} - \cos \frac{\pi n(2J_1+1)}{J_3+2} \right) \times \Delta_{x_1x_2}^2 \Delta_{x_1x_3}^{J_1} \Delta_{x_2x_3}^{J_2} (\Delta_{x_2x_3} + \Delta_{x_1x_3} - \Delta_{x_1x_3} \Delta_{x_2x_3} \Delta_{x_1x_2}^{-1}), \quad (3.19)$$

where we have used $\partial_\mu^{(x_3)} \Delta_{x_1x_3} \partial^{\mu(x_3)} \Delta_{x_2x_3} = -8\pi^2 (\Delta_{x_1x_3} \Delta_{x_2x_3}^2 + \Delta_{x_1x_3}^2 \Delta_{x_2x_3} - \Delta_{x_1x_3}^2 \Delta_{x_2x_3}^2 \Delta_{x_1x_2}^{-1})$. Inspecting (3.16), (3.17) and (3.19), it is immediate to notice that the first and the second terms in the second line of (3.19), which do not preserve conformal invariance, cancel the terms in (3.16) and (3.17) which are not proportional to J_1 and J_2 respectively. Then the contribution of the correlator involving the subleading term in $^{[4]}\mathcal{O}_n^{J_3}$ containing derivative impurities is finally:

$$A_3^{(SL_d)} = \frac{gN^{J_3+3}}{2^{J_3+2}\sqrt{2}} \Delta_{x_1x_2}^2 \Delta_{x_1x_3}^{J_1} \Delta_{x_2x_3}^{J_2} \left[2J_1 \sin \frac{2\pi n}{J_3+2} \Delta_{x_1x_3} + 2J_2 \sin \frac{2\pi n}{J_3+2} \Delta_{x_2x_3} + \sin^{-1} \frac{\pi n}{J_3+2} \left(\cos \frac{\pi n}{J_3+2} - \cos \frac{\pi n(2J_1+1)}{J_3+2} \right) \Delta_{x_1x_2}^{-1} \Delta_{x_1x_3} \Delta_{x_2x_3} \right]. \quad (3.20)$$

The correlator in (3.8), which is given by the sum of $A_3^{(L)}$, $A_3^{(SL_f)}$ and $A_3^{(SL_d)}$, is then equal to zero because the first line of (3.20) cancels the contribution in (3.12), coming from the leading term of the long operator, while the second line of (3.20) cancels exactly the contribution coming from the subleading term of $^{[4]}\mathcal{O}_n^{J_3}$ containing flavour impurities (3.14).

3.2 A correlator involving a level-three non-BPS operator

In this section, we consider a 3-point correlator which must be zero not just as a consequence of the $U(1)_Y$ bonus symmetry, but also because constrained to vanish by the supersymmetric Ward Identities. In particular we compute at order g the correlator

$$\mathcal{A}_{U(1)=2} = \langle \bar{\mathcal{O}}_0^{J_1}(x_1)^{[1]} \mathcal{O}_{0,\beta}^{J_2}(X_2)^{[3]} \mathcal{O}_{n,\alpha}^{J_3}(x_3) \rangle, \quad (3.21)$$

which involves the BPS highest weight operator, the level-one state obtained by the action of $Q_{1\beta}$ on $\text{Tr}[Z_2 Z^{J_2+1}]$:

$${}^{[1]}\mathcal{O}_{0,\beta}^{J_2,2Z_2} = \sum_{p=0}^{J_2} \text{Tr}[Z_2 Z^p \psi_\beta^2 Z^{J_2-p}] - \text{Tr}[\psi_\beta^3 Z^{J_2+1}], \quad (3.22)$$

and the level-three non-BPS operator in (2.4). In order to have a $\text{SU}(4)_R$ scalar, we must impose $J_1 = J_2 + J_3 + 1$.

One can argue that superconformal invariance constrains (3.21) to vanish. This can be seen by considering the sum of (3.21) with the two correlators obtained by moving the charge $Q_{4\alpha}$ on the two BPS operators. According to the supersymmetric Ward Identities, this sum should be zero. It is immediate to notice that $Q_{4\alpha}{}^{[1]}\mathcal{O}_{0,\beta}^{J_2,2Z_2} \propto Q_{1\beta} Q_{4\alpha} \text{Tr}[Z_2 Z^{J_2+1}] = 0$, hence one of the three correlators involved in the supersymmetric Ward Identities is identically zero. The two non-trivial correlators have the two fermionic operators in different positions: they are in x_2 and x_3 in the first correlator and in x_1 and x_2 in the second one. In general, conformal invariance fixes spacetime structure of the three point function between one scalar and two fermionic conformal primary operators to be

$$\langle \mathcal{O}_1(x_1) \mathcal{O}_{2,\alpha}(x_2) \mathcal{O}_{3,\beta}(x_3) \rangle = \frac{C_{123}(g, N)}{|x_{12}|^{\hat{\Delta}_1 + \hat{\Delta}_2 - \hat{\Delta}_3} |x_{13}|^{\hat{\Delta}_1 + \hat{\Delta}_3 - \hat{\Delta}_2} |x_{23}|^{\hat{\Delta}_2 + \hat{\Delta}_3 - \hat{\Delta}_1}} \epsilon^{\dot{\alpha}\dot{\beta}} \sigma_{\dot{\alpha}\dot{\alpha}}^\mu \sigma_{\dot{\beta}\dot{\beta}}^\nu \frac{(x_{12})_\mu (x_{13})_\nu}{x_{12}^2 x_{13}^2}, \quad (3.23)$$

where $x_{ij} = x_i - x_j$ and $\hat{\Delta}_i = \Delta_i - 1$ if the operator \mathcal{O}_i is a scalar, while $\hat{\Delta}_i = \Delta_i - \frac{1}{2}$ if \mathcal{O}_i is a fermion. Thus the sum of two possibly non-trivial correlators in our example can be zero only if they are separately zero. In the following, we will show this explicitly for the correlator in (3.21) up to order g .

Since there are no other $\text{SU}(4)$ structures that can contribute to the level three state, the orthogonality between it and the BPS state $\text{Tr}[\psi_3 Z^J]$, which we checked explicitly in section 2, ensures that it is also orthogonal to the supergravity state in (3.22). This is in agreement both with the $U(1)_Y$ selection rule for two-point correlators, and with conformal invariance, which forbids the overlap between operators with different scaling dimension. In fact the level-one BPS operator and the level-three non-BPS one involved in (3.21) have the same free scaling dimension $\Delta^{(0)} = J + \frac{5}{2}$, but this is no longer true at order $\mathcal{O}(g^2)$, when the scaling dimension of the non-BPS operator starts to get corrected by its anomalous part.

We can now move to the computation of the three-point function in (3.21). As in the previous section, let us rewrite the long operator as the sum of its leading plus subleading term ${}^{[3]}\mathcal{O}_{n,\alpha}^{J_3} = {}^{[3]}L_{n,\alpha}^{J_3} + g{}^{[3]}S_{n,\alpha}^{J_3}$, and let us first focus on the contribution coming from the leading term. Specifically, let us first focus on the contraction involving the second addend in the first line of (2.4) and the first term of the BPS state. We get:

$$A_3^{(1)} = \frac{1}{4\pi^2} \frac{gN^{J_1+1}}{2^{J_1}\sqrt{2}} \sin \frac{2\pi n}{J_3+2} \Delta_{x_2 x_3}^2 \Delta_{x_1 x_2}^{J_2} \Delta_{x_1 x_3}^{J_3} \epsilon^{\dot{\alpha}\dot{\beta}} \sigma_{\dot{\alpha}\dot{\alpha}}^\mu \sigma_{\dot{\beta}\dot{\beta}}^\nu \frac{(x_{13})_\mu (x_{12})_\nu}{x_{13}^2 x_{12}^2}, \quad (3.24)$$

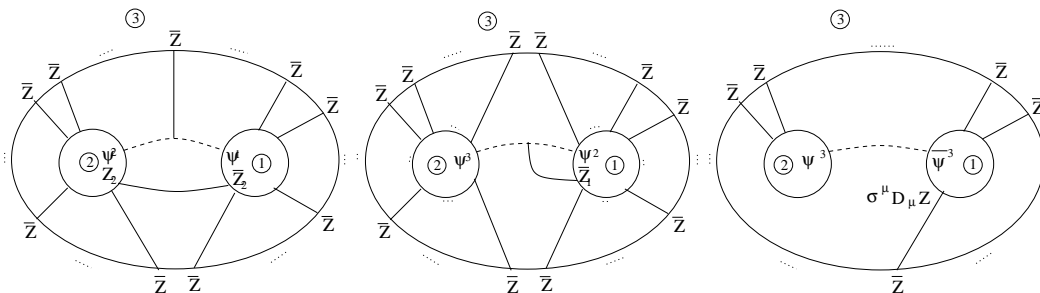

Figure 5. Diagrams contributing in the correlator (3.21). The diagram on the left originates from the contractions involving the leading term of the long operator and the first term of the BPS while the next diagram contributes to the contractions of leading term of the long operator and the second term of the BPS. The last diagram depicts the free contractions involving the sub leading term of the long operator and the second term of the short one.

where the integral over the position of the Yukawa coupling has been computed using eq. (B.1) of [19]. Comparing this result with (3.23), we notice that it takes exactly the form that conformal invariance requires for (3.21).

Both the addends in the leading term of the non-BPS state can further be contracted with the compensating term of the BPS one. These two contributions are equal, so let us just focus on one of them, e.g. that associated to the term containing ψ^2 and \bar{Z}_1 . One of the two corresponding diagrams is shown in figure 5. The other one can be obtained by exchanging the position of the impurities. Adding an extra factor of two to take into account the contribution of the term with ψ^1 and \bar{Z}_2 in (2.4), we get that the sum of these diagrams is:

$$A_3^{(2)} = -\epsilon_{\alpha\beta} \frac{gN^{J_1+1}}{2^{J_1}\sqrt{2}} \sin \frac{2\pi n}{J_3+2} \Delta_{x_2x_3}^2 \Delta_{x_1x_2}^{J_2+1} \Delta_{x_1x_3}^{J_3}. \quad (3.25)$$

All together we have $\langle \bar{\mathcal{O}}_0^{J_1 [1] \mathcal{O}_{0,\beta}^{J_2 [3] L_{n,\alpha}^{J_3}} \rangle = A_3^{(1)} + A_3^{(2)}$.

Notice, however, that $A_3^{(2)}$ does not take the form dictated by conformal invariance, and the only way to recast the spacetime structure in (3.23) is to cancel this contribution against similar terms coming from the free contraction of the subleading term in (2.4). This is given by:

$$g \langle \bar{\mathcal{O}}_0^{J_1 [1] \mathcal{O}_{0,\beta}^{J_2 [3] S_{n,\alpha}^{J_3}} \rangle = \frac{gN^{J_1+1}}{(4\pi^2)^3 2^{J_1} \sqrt{2}} \sin \frac{2\pi n}{J_3+2} \Delta_{x_1x_2}^{J_2+1} \Delta_{x_1x_3}^{J_3-1} \epsilon^{\dot{\alpha}\dot{\beta}} \sigma_{\alpha\dot{\alpha}}^\mu \sigma_{\beta\dot{\beta}}^\nu \frac{(x_{13})_\mu (x_{23})_\nu}{x_{13}^4 x_{23}^4} \quad (3.26)$$

Rewriting $x_{23} = x_{13} - x_{12}$ and using the relation $\epsilon^{\dot{\alpha}\dot{\beta}} \sigma_{\alpha\dot{\alpha}}^\mu \sigma_{\beta\dot{\beta}}^\nu = -\eta^{\mu\nu} \epsilon_{\alpha\beta} + 2\sigma^{\mu\nu\alpha\beta}$, it is immediate to show that the two terms that we get from (3.26) cancel respectively $A_3^{(1)}$ and $A_3^{(2)}$. As a result, the three-point correlator in (3.21) is zero at order g , in agreement with the requirements of the supersymmetric Ward Identities.

4 Contributions of the operator mixing to non-trivial structure constants

As we have just seen, the order g^2 corrections to the structure constants among gauge invariant operators may have a double origin: they derive both from the contraction involving

the leading term of the operators at one-loop and, in case of operator mixing, from the contraction involving the subleading terms at tree-level or at order g (this depending on the order the mixing occurs). The former contributions had been studied explicitly in different subsectors of the the full PSU(2, 2|4) invariant $\mathcal{N} = 4$ theory [6–9]. On the contrary, the contributions of the second kind have been predicted but not explicitly computed due to the lack of knowledge of the exact form of the non-BPS operators. Since we solved the mixing problem up to order g^2 , we can in principle evaluate explicitly in perturbation theory the structure constants involving BPS operators and one or more non-BPS operators with two impurities. In this section we do it this fact by concentrating on the computation of the contribution that the subleading mixing terms give to a non-trivial structure constant at order g^2 . For the sake of simplicity, we will focus again on a correlator between the highest weight in (2.1) and two BPS states:

$$\langle \mathcal{O}_0^{J_1, \bar{Z}_1 \bar{Z}_2}(x_1) \mathcal{O}_0^{J_2, Z_1 Z_2}(x_2) \bar{\mathcal{O}}_n^{J_3}(x_3) \rangle, \quad (4.1)$$

where \mathcal{O}_0^J are the operators in (3.9), and the constraint $J_3 = J_1 + J_2$ holds. Concentrating exclusively on the contraction at order g^2 of the subleading mixing terms of the long operator, it is immediate to notice that the computation follows closely that associated to the correlator (3.8). Two kinds of diagram contribute: those involving the contraction of the subleading terms in (2.1) with fermion impurities and a Yukawa coupling, and the three-level contraction of the term in (2.1) of order g^2 .

Focusing on the first case, the two subleading terms give the same result, since the different sign in front to the two order- g terms in (2.1) is compensated by the different sign in front to the Yukawa couplings involving fermions with different chirality. Hence, taking into account the correct multiplicity and the mixing coefficient, the result can be immediately read out from equation (3.12):

$$-\frac{g^2 N^{J_3+3}}{2^{J_3+3} \pi^2} \sin \frac{\pi n}{J_3+3} \sin \frac{4\pi n}{J_3+3} \Delta_{x_1 x_2}^2 \Delta_{x_1 x_3}^{J_1} \Delta_{x_2 x_3}^{J_2} (J_1 \Delta_{x_1 x_3} + J_2 \Delta_{x_2 x_3}) \quad (4.2)$$

where, again, we dropped the overall normalisation. In going from (3.12) to (4.2), we took into account the different number of background fields in the trace and of the different phase factors weighting the sums in the long operator.

Analogously, the three diagrams in figure 4 contributes to the tree-level contraction of the term of order g^2 . Taking into account the correct mixing coefficient and the different phase factor and number of Z in the trace with respect to the computation in section 3.1, we get that the sum of the three diagrams yields to:

$$\frac{g^2 N^{J_3+3}}{2^{J_3+8} \pi^4} \Delta_{x_1 x_2}^2 \left[32\pi^2 \sin \frac{4\pi n}{J_3+3} \sin \frac{\pi n}{J_3+3} \Delta_{x_1 x_3}^{J_1} \Delta_{x_2 x_3}^{J_2} (J_1 \Delta_{x_1 x_3} + J_2 \Delta_{x_2 x_3}) + \right. \\ \left. -8\pi^2 \left(\cos \frac{3\pi n}{J_3+3} - \cos \frac{\pi n(2J_1+3)}{J_3+3} \right) \Delta_{x_1 x_3}^{J_1+1} \Delta_{x_2 x_3}^{J_2+1} \Delta_{x_1 x_2}^{-1} \right]. \quad (4.3)$$

The first line of (4.3) cancels exactly the contribution in (4.2), thus ensuring conformal invariance. Then, restoring the proper normalisation the contribution to the one loop

structure constant coming from the subleading mixing terms of the long operator is:

$$\frac{(-1)^{J_3} g^2}{\sqrt{J_1 J_2 (J_3 + 3)} 4\pi^2} \left(\cos \frac{3\pi n}{J_3 + 3} - \cos \frac{\pi n (2J_1 + 3)}{J_3 + 3} \right) \frac{1}{x_{12}^2 x_{13}^{2(J_1+1)} x_{23}^{2(J_2+1)}}. \quad (4.4)$$

The complete structure constants at order g^2 are then obtained by adding the result in (4.4) to the contribution coming from the contraction between the leading term of $\mathcal{O}_n^{J_3}$ and the two BPS states at one-loop. Since this computation falls completely in the SO(6) scalar subsector of $\mathcal{N} = 4$ SYM, it can be performed adopting the prescription in [6, 8]. It consists into splitting the one loop coefficient into a sum of terms, each associated to one of the three operators. Each such term can be obtained including in the correlator an effective vertex. This is proportional to the SO(6) spin chain Hamiltonian at one loop and it is constrained to planarly connect two neighbour “letters” of the operator it acts on with two “letters” split between the remaining two operators. Notice that, since the states in the non-BPS multiplet of section 2 are not restricted to some subsector of $\mathcal{N} = 4$ SYM, they are natural candidates to study the possible extension of the technique in [6, 8] to describe the quantum corrections to the structure constant between gauge invariant operators in the full PSU(2, 2|4) theory. This would require the full PSU(2, 2|4) spin chain Hamiltonian, which is known up to one-loop, and which does not have any terms of order g . Thus, it is not clear how to include in this description the possible order g corrections to the structure constant coming from the contraction of, e.g., two fermionic operators with a Yukawa coupling.

5 Structure constants in the BMN limit

The BMN limit is a truncation of the full AdS₅ × S⁵ IIB string theory which selects the states with a large angular momentum J along one direction in the five sphere. It requires a double scaling limit where the both λ and J are scaled to infinity, but the ratio $\lambda' = \lambda/J^2$ is finite. This limit has two virtues for our purposes: firstly, in contrast with the supergravity approximation, both BPS and non-BPS states are present in the spectrum. Secondly, contrary to the full AdS₅ × S⁵ theory, the world-sheet dynamics is described in the light-cone gauge by a free Lagrangian. The spectrum for BMN strings can be constructed by using two towers of eight bosonic (a_n^\dagger) and eight fermionic (b_n^\dagger) harmonic oscillators transforming in the vector and spinor representation respectively of the SO(4) × SO(4) group which commutes with the angular momentum J . Each free string is characterised by the light-cone momentum p^+ and the energy, which is simply the sum of the usual harmonic oscillators energy for the modes a_n^\dagger, b_n^\dagger . The frequency of these modes ω_n depends on a mass parameter μ describing the PP-wave geometry: $\omega_n = \sqrt{n^2 + (\mu\alpha'p^+)^2}$. We will not recall the technical details of the light-cone description of string theory on the relevant PP-wave geometry [35, 36] and refer to [37] and references therein for the definition of all symbols used in this section.

As mentioned in the introduction, the description of BMN string theory was pushed beyond the free theory and the cubic corrections to the light-cone Hamiltonian were studied in details. Exactly as in the flat-space case, the quadratic Hamiltonian H_2 captures the

stationary wave solutions of the free equation of motions and their energy, while the cubic Hamiltonian H_3 gives the 3-point couplings between these stationary waves. This can be checked explicitly when all external states are supergravity modes by taking the large J limit of the $\text{AdS}_5 \times S^5$ Hamiltonian. Of course this means that the results read from H_3 are not directly the structure constants of the CFT, since in the bulk description these are given by a different overlap integral which involves the boundary to bulk propagators. However the two results are related, since both of them are proportional to the cubic couplings in the AdS_5 effective action. Again this can be checked explicitly in the supergravity sector [15] and one finds the relation between H_3 and the structure constants first introduced in [14]. It is natural to expect that these two approaches are strictly related even in the non-BPS sector and we expect that a particular structure constant can vanish only if the corresponding element of H_3 vanishes. Thus it is interesting to check whether the $U(1)_Y$ selection rule and the other constraints discussed in the introduction hold for the cubic Hamiltonian H_3 .

At the supergravity level, the $U(1)_Y$ symmetry is exact and so it should be possible to construct a cubic Hamiltonian that preserves in this sector the $U(1)_Y$ quantum number. This has been done [15], where it was also checked that the result obtained is consistent with the large J limit of the $\text{AdS}_5 \times S^5$ Hamiltonian. Then the complete cubic Hamiltonian can be derived by requiring that it respects all the (super)symmetries of the PP-wave background and reduces to the known results when truncated to the BPS sector. The final expression is given in eq. (4.6) of [15]. Thus we want to check if this cubic Hamiltonian is consistent with the various results constraining the interaction between two BPS and one non-BPS states.

From the examples discussed on the gauge theory side we expect that the mixing between non-BPS states with the same quantum number should play a crucial role. This mixing was resolved in [19] for the 2-impurity HWS in the PP-wave string theory, which corresponds to the SYM operator in (2.1). The result is given by⁴

$$|n\rangle = \frac{1}{4(1+U_n^{-2})} \left[a_n^{\dagger i'} a_n^{\dagger i'} + a_{-n}^{\dagger i'} a_{-n}^{\dagger i'} + 2U_n^{-1} b_{-n}^{\dagger} \Pi b_n^{\dagger} - U_n^{-2} \left(a_n^{\dagger i} a_n^{\dagger i} + a_{-n}^{\dagger i} a_{-n}^{\dagger i} \right) \right] |\alpha < 0\rangle, \quad (5.1)$$

where we refer to [19] for the details of the derivation and definition of U_n and Π . Thus a first example of a $U(1)_Y$ violating process for the PP-wave cubic Hamiltonian is given by the interaction of this highest weight state and two supergravity states. This interaction corresponds to the gauge theory correlator (3.1). Also on the string side, this process receives two types of contribution. One comes from the bosonic oscillators (a_n^{\dagger}), while the other from the fermionic ones (b_n^{\dagger}). By using the properties of the various constituents of the cubic Hamiltonian H_3 and of the string state (5.1) we checked that these two contributions precisely cancel and thus the total amplitude vanishes.

A closely related question is whether or not the three-point function coefficients, as obtained from the cubic PP-wave Hamiltonian, respect the constraints derived from the

⁴Notice that the discussion in [19] refers to the HWS state with positive light-cone momentum α , while here we write the HWS state with negative α and this is the reason for the slightly different form of (5.1).

superconformal invariance of the $\mathcal{N} = 4$ theory [22, 26, 27]. In order to address this question, we examine the following two string amplitudes. In the first one the highest weight state of (5.1) splits to two vacuum states. We checked that also this amplitude vanishes in a non-trivial way: the contribution coming from the bosonic part of the non-BPS state precisely cancels against that of the fermionic part. The situation changes if one considers the overlap between the HWS and two BPS states with one scalar impurity each, namely

$$a_{0(2)}^{\dagger Z_1} |\alpha_2\rangle, \quad a_{0(1)}^{\dagger \bar{Z}_1} |\alpha_1\rangle. \quad (5.2)$$

The structure constants among these states should vanish according to [22, 26, 27]. However, in this case, the contribution involving the bosonic terms of the non-BPS string state cancels only part of the contribution of the terms with the fermionic oscillators. Consequently, the string amplitude associated to this process is non-zero⁵:

$$-2C_{123}^{(0)} N_{nn}^{33} N_{00}^{12}, \quad (5.3)$$

where we use the conventions of [15] and references therein.

In the next example, we consider the string version of the second correlator discussed in section 3.1. In order to compute the value of the cubic Hamiltonian for this case, we need first to fix the form of the string state corresponding to the operator (2.12). As before, this is done by checking that the string state is annihilated by the same supercharges of the gauge theory operator and the result is

$$|n\rangle^{[4]} = \frac{1}{4(1 + U_n^{-2})} \left[b_{-n}^{\dagger} (1 + \Pi) b_n^{\dagger} + U_n^{-2} b_{-n}^{\dagger} (1 - \Pi) b_n^{\dagger} - U_n^{-1} \left(a_n^{\dagger i'} a_n^{\dagger i'} + a_n^{\dagger i} a_n^{\dagger i} + (n \rightarrow -n) \right) \right] |\alpha\rangle, \quad (5.4)$$

As a warming up exercise, we computed the amplitude describing the splitting of the non-BPS state (5.4) into two strings in the ground state (which is annihilated by all destruction operators a, b). Again the contributions of the terms with bosonic and fermionic impurities in (5.4) are non-trivial. After using the properties of the constituents in H_3 , it is possible to check that these two contributions are one the opposite of the other. So the cubic Hamiltonian is again zero for this $U(1)_Y$ violating process. We did not consider explicitly this example on the gauge theory side, because the corresponding correlator receives contributions from some extremal diagrams and so, in order to have a reliable result for the structure constants, one would need to resolve also the $1/N$ mixing with double trace operators.

Now we can turn to the string amplitude that really corresponds to the correlator (3.8). It is described by the splitting of the state (5.4) into two BPS states with two bosonic impurities each

$$a_{0(2)}^{\dagger Z_1} a_{0(2)}^{\dagger Z_2} |\alpha_2\rangle, \quad a_{0(1)}^{\dagger \bar{Z}_1} a_{0(1)}^{\dagger \bar{Z}_2} |\alpha_1\rangle. \quad (5.5)$$

⁵Notice that this is not in contrast with the result derived in [38]: if we apply the usual dictionary between structure constants and the PP-wave Hamiltonian, the result in (5.3) vanishes in the $\lambda' \rightarrow 0$ limit and the first non-trivial contribution to this particular structure constant is at order $\mathcal{O}(\lambda')$.

There are two kinds of contributions for this process. The first possibility is to contract the impurities in (5.5) with H_3 in such a way that there is no mixing with the oscillators in the non-BPS state. These contributions will cancel as in the previous example. Secondly, there are the contributions where the oscillators of the BPS and the non-BPS states are mixed together non-trivially. In the string analysis they can involve only the oscillators with indices in the “flavour” $SO(4)$, *i.e.* the oscillator that in the standard BMN dictionary between string and gauge theory impurities correspond to the insertion of scalar fields. The result for this case is

$$-\frac{C_{123}^{(0)}}{1+U_{n(3)}^{-2}}U_{n(3)}^{-1}2\left(2+\frac{\omega_{n(3)}}{\mu\alpha_3}\right)N_{0n}^{13}N_{0n}^{23}N_{00}^{12} \quad (5.6)$$

Apparently the cubic Hamiltonian discussed in [15] does not have room for a contribution corresponding to the field theory diagrams in figure 4, where the oscillators with indices i, j in the non-BPS strings are contracted with oscillators with indices i', j' in the BPS state. Thus the PP-wave cubic Hamiltonian is non-zero in this case.

6 Discussion and conclusions

In this paper we studied the structure constants of $\mathcal{N} = 4$ SYM by focusing in particular on those cases where two of the states are half-BPS and one is a part of a generic long multiplet. On the gauge theory side of the AdS/CFT we used standard planar perturbation theory and explicitly computed various examples. On the string theory side we relied on the BMN limit of the $AdS_5 \times S^5$ IIB string theory and computed the 3-string interactions corresponding to some of the gauge theory correlators previously analysed. The regime of validity of these computations is complementary: the BMN string theory is a reliable approximation of the full $AdS_5 \times S^5$ in the limit $\lambda, J \rightarrow \infty$ with λ' fixed, while perturbative gauge theory computations require $\lambda \ll 1$. We showed that the mixing discussed in [19] plays a crucial role in both string and gauge theories computations and the final result for the 3-point amplitudes depends on the mixing coefficients, even if these coefficients cannot be fixed simply by using the standard approach of diagonalising the 2-point correlators. This does not come as a surprise, since the states transform correctly under the relevant superalgebra only when the mixing has been appropriately taken into account.

We paid particular attention to the constraints on the 3-point function following from the $U(1)_Y$ bonus symmetry [21], the OPE's of the 4-point correlators among BPS states [22] and the superspace approach to the $\mathcal{N} = 4$ SYM [24–28]. Our explicit field theory computations are performed in components and thus do not keep the superconformal invariance explicit; nevertheless all our field theory results are consistent with the constraints just mentioned thanks to non-trivial cancellations involving the mixing discussed above.

All constraints that follow from symmetry reasons should be valid at all orders in the 't Hooft coupling and thus should be manifest also in the relevant string computations. However, the situation is less clear on the string side of the correspondence. In section 5 we discussed various examples of 3-string interactions in the BMN limit (again with two BPS and one non-BPS strings). Again some possible of the violating 3-point couplings vanish

thanks to some “miraculous” cancellations which follow from the mixing discussed in [19]. However, in the same section, we have other examples of 3-point amplitudes that violate either the $U(1)_Y$ bonus symmetry or the constraints following from the superconformal Ward Identities. In these cases the cancellations among the various terms generated in the string computations are not complete. Of course, it would be very interesting to understand better the source of this mismatch and we hope to come back to this point in the future. One possibility is that the PP-wave cubic Hamiltonian [15] does not capture the structure constants beyond the BPS sector either because some terms are missing or because the holographic relation with CFT structure constants is more complicated than what is currently believed.

In order to understand whether one of these two possibilities is indeed correct, it would be clearly helpful to study the structure constants at strong coupling without relying on the BMN limit. As mentioned in the introduction, an approach that has been used to analyse the $\mathcal{N} = 4$ structure constants at strong coupling is to study the OPE’s of the 4-point function among BPS operators [39]. This approach cannot be used to isolate each single structure constant with a non-BPS state, since at strong coupling these states develop large anomalous dimensions and decouple. However, it is possible to compute the 4-point functions in the bulk by using also the first non-trivial string corrections to the IIB supergravity and this should give some information about the strong coupling behaviour of the 3-point function under study. A large class of string corrections in type IIB have been explicitly written in a $SL(2, Z)$ covariant form in [29] and at least one term appears to violate the conservation of the $U(1)_Y$ charge. A term of this type in the string corrected supergravity action is likely to induce unexpected $U(1)_Y$ violating amplitudes when used to compute Witten’s diagrams in AdS. Of course, it would be very interesting to capture some information about the structure constants at strong coupling directly by using $AdS_5 \times S^5$ string theory. This appears to be a challenging task, since, in this case, not even the spectrum is known in detail. However by using the pure spinor formalism [40] it might be possible at least to see whether the $U(1)_Y$ selection rule is a consequence of a zero-mode counting and hopefully to clarify the connections between the full $AdS_5 \times S^5$ computation and the results in the PP-wave and the supergravity limits.

Acknowledgments

We wish to thank N. Beisert, P. Heslop, K. Intriligator, S. Kovacs, G. Policastro and Y. Stanev for useful discussions and comments. The work of V. Gili is supported by the Foundation Boncompagni-Ludovisi. This work is partially supported by STFC under the Rolling Grant ST/G000565/1.

References

- [1] J.M. Maldacena, *The large- N limit of superconformal field theories and supergravity*, *Adv. Theor. Math. Phys.* **2** (1998) 231 [*Int. J. Theor. Phys.* **38** (1999) 1113] [[hep-th/9711200](#)] [[SPIRES](#)].

- [2] S.S. Gubser, I.R. Klebanov and A.M. Polyakov, *Gauge theory correlators from non-critical string theory*, *Phys. Lett. B* **428** (1998) 105 [[hep-th/9802109](#)] [[SPIRES](#)].
- [3] E. Witten, *Anti-de Sitter space and holography*, *Adv. Theor. Math. Phys.* **2** (1998) 253 [[hep-th/9802150](#)] [[SPIRES](#)].
- [4] S. Lee, S. Minwalla, M. Rangamani and N. Seiberg, *Three-point functions of chiral operators in $D = 4$, $N = 4$ SYM at large- N* , *Adv. Theor. Math. Phys.* **2** (1998) 697 [[hep-th/9806074](#)] [[SPIRES](#)].
- [5] M. Bianchi, S. Kovacs, G. Rossi and Y.S. Stanev, *Properties of the Konishi multiplet in $N = 4$ SYM theory*, *JHEP* **05** (2001) 042 [[hep-th/0104016](#)] [[SPIRES](#)].
- [6] K. Okuyama and L.-S. Tseng, *Three-point functions in $N = 4$ SYM theory at one-loop*, *JHEP* **08** (2004) 055 [[hep-th/0404190](#)] [[SPIRES](#)].
- [7] R. Roiban and A. Volovich, *Yang-Mills correlation functions from integrable spin chains*, *JHEP* **09** (2004) 032 [[hep-th/0407140](#)] [[SPIRES](#)].
- [8] L.F. Alday, J.R. David, E. Gava and K.S. Narain, *Structure constants of planar $N = 4$ Yang-Mills at one loop*, *JHEP* **09** (2005) 070 [[hep-th/0502186](#)] [[SPIRES](#)].
- [9] L.F. Alday, J.R. David, E. Gava and K.S. Narain, *Towards a string bit formulation of $N = 4$ super Yang- Mills*, *JHEP* **04** (2006) 014 [[hep-th/0510264](#)] [[SPIRES](#)].
- [10] D.E. Berenstein, J.M. Maldacena and H.S. Nastase, *Strings in flat space and pp waves from $N = 4$ super Yang-Mills*, *JHEP* **04** (2002) 013 [[hep-th/0202021](#)] [[SPIRES](#)].
- [11] M. Spradlin and A. Volovich, *Superstring interactions in a pp-wave background*, *Phys. Rev. D* **66** (2002) 086004 [[hep-th/0204146](#)] [[SPIRES](#)].
- [12] A. Pankiewicz and J. Stefanski, B., *pp-wave light-cone superstring field theory*, *Nucl. Phys. B* **657** (2003) 79 [[hep-th/0210246](#)] [[SPIRES](#)].
- [13] P. Di Vecchia, J.L. Petersen, M. Petrini, R. Russo and A. Tanzini, *The 3-string vertex and the AdS/CFT duality in the pp-wave limit*, *Class. Quant. Grav.* **21** (2004) 2221 [[hep-th/0304025](#)] [[SPIRES](#)].
- [14] S. Dobashi and T. Yoneya, *Resolving the holography in the plane-wave limit of AdS/CFT correspondence*, *Nucl. Phys. B* **711** (2005) 3 [[hep-th/0406225](#)] [[SPIRES](#)].
- [15] S. Lee and R. Russo, *Holographic cubic vertex in the pp-wave*, *Nucl. Phys. B* **705** (2005) 296 [[hep-th/0409261](#)] [[SPIRES](#)].
- [16] N. Beisert, C. Kristjansen, J. Plefka, G.W. Semenoff and M. Staudacher, *BMN correlators and operator mixing in $N = 4$ super Yang-Mills theory*, *Nucl. Phys. B* **650** (2003) 125 [[hep-th/0208178](#)] [[SPIRES](#)].
- [17] N.R. Constable, D.Z. Freedman, M. Headrick and S. Minwalla, *Operator mixing and the BMN correspondence*, *JHEP* **10** (2002) 068 [[hep-th/0209002](#)] [[SPIRES](#)].
- [18] N. Beisert, *BMN operators and superconformal symmetry*, *Nucl. Phys. B* **659** (2003) 79 [[hep-th/0211032](#)] [[SPIRES](#)].
- [19] G. Georgiou, V.L. Gili and R. Russo, *Operator mixing and the AdS/CFT correspondence*, *JHEP* **01** (2009) 082 [[arXiv:0810.0499](#)] [[SPIRES](#)].
- [20] K.A. Intriligator, *Bonus symmetries of $N = 4$ super-Yang-Mills correlation functions via AdS duality*, *Nucl. Phys. B* **551** (1999) 575 [[hep-th/9811047](#)] [[SPIRES](#)].

- [21] K.A. Intriligator and W. Skiba, *Bonus symmetry and the operator product expansion of $N = 4$ super-Yang-Mills*, *Nucl. Phys. B* **559** (1999) 165 [[hep-th/9905020](#)] [[SPIRES](#)].
- [22] M. Nirschl and H. Osborn, *Superconformal Ward identities and their solution*, *Nucl. Phys. B* **711** (2005) 409 [[hep-th/0407060](#)] [[SPIRES](#)].
- [23] F.A. Dolan, M. Nirschl and H. Osborn, *Conjectures for large- N $N = 4$ superconformal chiral primary four point functions*, *Nucl. Phys. B* **749** (2006) 109 [[hep-th/0601148](#)] [[SPIRES](#)].
- [24] B. Eden, P.S. Howe and P.C. West, *Nilpotent invariants in $N = 4$ SYM*, *Phys. Lett. B* **463** (1999) 19 [[hep-th/9905085](#)] [[SPIRES](#)].
- [25] P.S. Howe, C. Schubert, E. Sokatchev and P.C. West, *Explicit construction of nilpotent covariants in $N = 4$ SYM*, *Nucl. Phys. B* **571** (2000) 71 [[hep-th/9910011](#)] [[SPIRES](#)].
- [26] B. Eden and E. Sokatchev, *On the OPE of 1/2 BPS short operators in $N = 4$ SCFT(4)*, *Nucl. Phys. B* **618** (2001) 259 [[hep-th/0106249](#)] [[SPIRES](#)].
- [27] P.J. Heslop and P.S. Howe, *OPEs and 3-point correlators of protected operators in $N = 4$ SYM*, *Nucl. Phys. B* **626** (2002) 265 [[hep-th/0107212](#)] [[SPIRES](#)].
- [28] P.J. Heslop and P.S. Howe, *Aspects of $N = 4$ SYM*, *JHEP* **01** (2004) 058 [[hep-th/0307210](#)] [[SPIRES](#)].
- [29] G. Policastro and D. Tsimpis, *A note on the quartic effective action of type IIB superstring*, *Class. Quant. Grav.* **26** (2009) 125001 [[arXiv:0812.3138](#)] [[SPIRES](#)].
- [30] G. Policastro and D. Tsimpis, *R^4 , purified*, *Class. Quant. Grav.* **23** (2006) 4753 [[hep-th/0603165](#)] [[SPIRES](#)].
- [31] C.-S. Chu, V.V. Khoze and G. Travaglini, *Three-point functions in $N = 4$ Yang-Mills theory and pp - waves*, *JHEP* **06** (2002) 011 [[hep-th/0206005](#)] [[SPIRES](#)].
- [32] M. Bianchi, G. Rossi and Y.S. Stanev, *Surprises from the resolution of operator mixing in $N = 4$ SYM*, *Nucl. Phys. B* **685** (2004) 65 [[hep-th/0312228](#)] [[SPIRES](#)].
- [33] F.A. Dolan and H. Osborn, *On short and semi-short representations for four dimensional superconformal symmetry*, *Ann. Phys.* **307** (2003) 41 [[hep-th/0209056](#)] [[SPIRES](#)].
- [34] N. Beisert, *The $SU(2|2)$ dynamic S -matrix*, *Adv. Theor. Math. Phys.* **12** (2008) 945 [[hep-th/0511082](#)] [[SPIRES](#)].
- [35] R.R. Metsaev, *Type IIB Green-Schwarz superstring in plane wave Ramond-Ramond background*, *Nucl. Phys. B* **625** (2002) 70 [[hep-th/0112044](#)] [[SPIRES](#)].
- [36] R.R. Metsaev and A.A. Tseytlin, *Exactly solvable model of superstring in plane wave Ramond-Ramond background*, *Phys. Rev. D* **65** (2002) 126004 [[hep-th/0202109](#)] [[SPIRES](#)].
- [37] A. Pankiewicz, *Strings in plane wave backgrounds*, *Fortsch. Phys.* **51** (2003) 1139 [[hep-th/0307027](#)] [[SPIRES](#)].
- [38] C.-S. Chu and V.V. Khoze, *Correspondence between the 3-point BMN correlators and the 3-string vertex on the pp -wave*, *JHEP* **04** (2003) 014 [[hep-th/0301036](#)] [[SPIRES](#)].
- [39] G. Arutyunov, S. Frolov and A.C. Petkou, *Operator product expansion of the lowest weight CPOs in $N = 4$ SYM(4) at strong coupling*, *Nucl. Phys. B* **586** (2000) 547 [[hep-th/0005182](#)] [[SPIRES](#)].
- [40] N. Berkovits, *Simplifying and extending the $AdS_5 \times S^5$ pure spinor formalism*, *JHEP* **09** (2009) 051 [[arXiv:0812.5074](#)] [[SPIRES](#)].